

Your excellent helper in cable test!

NF-859G Series

Multi-functional Wire Detector User Manual



Your excellent helper in cable test!



VER: V2

CONTENTS

NF-859G

NF-859G Keys and Interfaces.....	01
User Instructions.....	02
1. Alignment Test.....	02
2. Wire Detection (used with other models).....	03
3. Crimping Test.....	03
4. PoE Power Supply Wire Core Connection Test.....	03
5. Optical Fiber Fault Detector Function.....	04
6. Flashlight Function.....	04
7. Battery Indication.....	04
Product Parameters.....	05
Packing List.....	05

NF-859GE (859G+802G Transmitter)

NF-859GE Keys and Interfaces.....	06
User Instructions.....	07
1. Wire Detection.....	07
2. Alignment Test.....	07
3. Crimping Test.....	08
4. Port Blinking.....	09
5. Telephone Line Detection.....	09
Product Parameters.....	10

NF-859GS (859G+8209S Transmitter)

NF-859GS Keys and Interfaces.....	11
User Instructions.....	12
1. Power-on and Power-off.....	12
2. Alignment Test Function.....	12
3. Length Test.....	13
4. Wire Detection Function.....	14
5. PoE Test Function.....	15
6. Port Blinking Function/Link Test.....	15
7. Crimping Test.....	16
8. Transmitter Setup Function.....	16
Product Parameters.....	17
Simple Fault Description.....	19

NF-859GK (859G+8506 Transmitter)

NF-859GK Keys and Interfaces.....20
 Icons on UI.....21
 User Instructions.....22
 1. Alignment Test.....22
 2. Wire Detection.....23
 3. Port Blinking.....24
 4. Network Line Length Test.....24
 5. PoE Test Function.....25
 6. PING Test Function.....25
 7. IP Scanning Function.....26
 8. Network Port Rate Test.....26
 9. Transmitter Setup Function.....26
 Product Parameters.....27

NF-859GT (859G+8508 Transmitter)

NF-859GT Keys and Interfaces.....28
 Icons on UI.....29
 User Instructions.....30
 1. Alignment Test.....30
 2. Wire Detection.....31
 3. Port Blinking.....32
 4. Network Line Length Test.....32
 5. PoE Test Function.....33
 6. Crimping Test.....33
 7. Optical Power Meter Function.....34
 8. Red Light Function.....36
 9. Setup Function.....36
 Product Parameters.....37

NF-859G

Main Functions: Alignment test, crimping test, PoE power supply circuit detection, optical fiber fault detector function, flashlight function, and wire detection with other models of NOYafa.

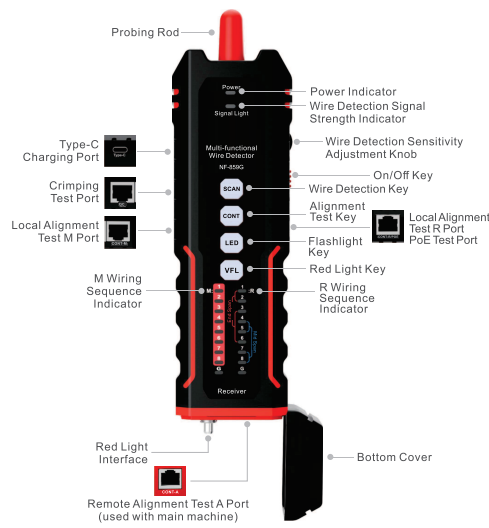

Overview

User Instructions

1. Alignment Test

① Local Alignment Test

Insert one end of the network line under test into the "Local Alignment Test M" port on the left side of the receiver and the other end into the "Local Alignment Test R/PoE" port on the right side of the receiver. Press the "ECCM" key to start alignment test (give it a short press on the Alignment Test key to switch between fast/slow alignment test).

Access: The M wiring sequence indicators and R wiring sequence indicators give a flicker of green one by one accordingly.

M Wiring Sequence Indicators: 1-2-3-4-5-6-7-8
R Wiring Sequence Indicators: 1-2-3-4-5-6-7-8

Cross: Take the cross of 2 and 5 as an example. When the No. 2 M Wiring Sequence Indicator lights up, the No. 5 R Wiring Sequence Indicator will light up. When the No. 5 M Wiring Sequence Indicator lights up, the No. 2 R Wiring Sequence Indicator will light up.

M Wiring Sequence Indicators: 1-2-3-4-5-6-7-8
R Wiring Sequence Indicators: 1-5-3-4-2-6-7-8

Open Circuit: Take the open circuit of 2 as an example. The No. 2 wiring sequence indicator does not light up, and other wiring sequence indicators blink normally.

M Wiring Sequence Indicators: 1-X-3-4-5-6-7-8
R Wiring Sequence Indicators: 1-X-3-4-5-6-7-8

Short Circuit: Take the short-circuit of 2 and 5 as an example. When No. 2 or 5 M Wiring Sequence Indicator lights up, No. 2 and 5 R Wiring Sequence Indicators will light up at the same time, but are dark.

M Wiring Sequence Indicators: 1-2-3-4-5-6-7-8
R Wiring Sequence Indicators: 1-2-3-4-5-6-7-8

M Wiring Sequence Indicators: 1-2-3-4-5-6-7-8
R Wiring Sequence Indicators: 1-2-3-4-5-6-7-8

② Remote Alignment Test

On the right side of the instrument, there is a "Local Line R" port, which can be used for line testing with the 802 transmitter.
At the bottom of the instrument, there is a "Remote Line A" port, which can be used for line testing with 8209S/8506/8508 transmitters.

2. Wire Detection (used with other models)

When the instrument is powered on, the default mode is the anti-interference wire detection mode. Press the "ECCM" key to switch between the ordinary wire detection mode and the anti-interference wire detection mode.

Anti-Interference Wire Detection: The green light of the "ECCM" key is on. The stronger the signal, the brighter the indicator.

Ordinary Wire Detection: The green light of the "ECCM" key blinks. The stronger the signal, the brighter the indicator.

Note: The anti-interference wire detection mode is recommended for on-load wire detection; the ordinary wire detection mode is recommended for no-load wire detection.

3. Crimping Test

When the instrument is powered on, the crimping test function will begin automatically. Insert the registered jack into the crimping test port on the side of the instrument. If an M wiring sequence indicator lights up, it indicates that the corresponding wire core crimping is good; if no M wiring sequence indicator lights up, it indicates that the crimping is poor.

Note: The crimping test function is used to test whether the registered jack is through only and cannot judge whether the wiring sequence is correct. To test the wiring sequence, please use the alignment test function.

4. PoE Power Supply Wire Core Connection Test

Insert one end of the network line into the "Local Alignment Test R/PoE" port on the right side of the receiver and the other end into the PoE operating. The test results are as follows:

- ※ When the 1/2 or 3/6 indicators light up, it indicates that the PoE adopts the end-span method (i.e. 12/36 wire cores power supply).
- ※ When the 4/5 or 7/8 indicators light up, it indicates that the PoE adopts the mid-span method (i.e. 45/78 wire cores power supply).
- ※ When the 1/2 or 3/6 + 4/5 or 7/8 indicators light up, it indicates that the PoE adopts 8-core power supply.

Note: The pin line with the indicator lighting up in the above description is a positive electrode.

5. Optical Fiber Fault Detector Function

Press the "VFL" key to turn on the optical fiber fault detector function. Press it again to switch between On, Blink and Off.

6. Flashlight Function

Press the "LED" key to turn on/off the LED flashlight.

7. Battery Indication

- ① When the battery is too low, the power indicator will blink. Please timely charge the instrument.
- ② During charging, the power indicator will give a green light.
- ③ When the instrument is fully charged, the green light will go out.

Product Parameters

Model	NF-859G
Wire Detection Function	Anti-interference mode/ordinary mode (used with other models)
Alignment Test	Local alignment test and remote alignment test
Crimping Test	To test whether the registered jacks RJ11 and RJ45 are crimped properly
PoE	Power supply wire core, mid-span and end-span
VFL	10mW
LED Flashlight	✓
Battery Indication	✓
Power Supply	3.7V lithium polymer battery
Dimension of Receiver	200x52x33mm

Packing List

NF-859G	1 set	Toolkit	1 pcs
User Manual	1 pcs	Graphic carton	1 pcs
Lithium Battery Precautions Card	1 pcs	Conformity Certificate/Warranty Card	1 pcs
Type-C Data Cable	1 pcs		

Note: The manual is for reference only and is subject to change without notice. The real product shall control.

NF-859GE (859G+802G Transmitter)

The functions of the transmitter include alignment test, wire detection, crimping test and port blinking functions. In addition, the polarity of a telephone line as well as the Idle, Offhook and Ringing states can be tested.



Use Instructions

1. Wire Detection

- ① Once the transmitter is powered on, it will enter the wire detection mode. Here, the light of the Wire Detection key is on.
- ② Insert one end of the target line into the RJ45/RJ11 wire detection interface on the top of the transmitter.
- ③ Power on the receiver and turn on the wire detection function. Use the probe head to find the target line. When a signal is received, the instrument will beep and the signal strength indicator will give a light.

Techniques for Wire Detection:

- ① First, increase the sensitivity of the receiver to quickly judge the approximate range; then decrease the sensitivity for precise locating.
- ② The closer to the target, the stronger the signal, and the brighter the signal indicator light.
- ③ **Unique feature of NF-859GE:** Integrated line tracing/line testing mode. After tracing the line, line testing can be directly performed without operating the transmitter, greatly improving work efficiency!

2. Alignment Test

The transmitter defaults to the integrated line tracing/line testing mode when turned on, with the line tracing button lit continuously. Press the "SCAN" button briefly to switch to line testing mode, and the line tracing button will flash. Press the button again briefly to return to the integrated line tracing/line testing mode.

Insert one end of the network line under test into the RJ45 interface on the top of the transmitter and the other end into the "Local Alignment Test R Port" on the right side of the receiver. The condition of the cable is judged through the wiring sequence indicators as follows:

Circuit: The transmitter and receiver line sequence lights flash green one by one.

Transmitter: 1-2-3-4-5-6-7-8
Receiver: 1-2-3-4-5-6-7-8

Cross: Take the cross of 2 and 5 as an example. When the No. 2 wiring sequence indicator on the transmitter lights up, the No. 5 indicator on the receiver will light up. When the No. 5 indicator on the transmitter lights up, the No. 2 indicator on the receiver will light up.

Transmitter: 1-2-3-4-5-6-7-8
Receiver: 1-5-3-4-2-6-7-8

Open Circuit: Take the open circuit of 2 as an example. The No. 2 wiring sequence indicator does not light up, and other wiring sequence indicators blink normally.

Transmitter: 1-X-3-4-5-6-7-8
Receiver: 1-X-3-4-5-6-7-8

Short circuit: Taking pins 2 and 5 shorted as an example, the transmitter line sequence light flashes normally, while pins 2 and 5 on the receiver do not light up.

Transmitter: 1-2-3-4-5-6-7-8 **Transmitter:** 1-2-3-4-5-6-7-8
Receiver: 1-2-3-4-5-6-7-8 **Receiver:** 1-2-3-4-5-6-7-8

3. Crimping Test

Press the "CC" key on the transmitter to enter the crimping test mode. Here, the light of the Crimping key is on. Insert the registered jack into the crimping interface on the right side of the transmitter. Here, the crimping indicator will also light up. The judgement is as follows:

Network Line:

① **Normal:** All the crimping indicators on the transmitter light up.

Transmitter: 1-2-3-4-5-6-7-8

② **Example:** If Line 2 is not crimped properly, the No. 2 indicator does not light up and other indicators light up.

Transmitter: 1-x-3-4-5-6-7-8

Telephone Line:

① 6P6C in good condition: x-2-3-4-5-6-7-x

② 6P4C in good condition: x-x-3-4-5-6-x-x

③ 6P2C in good condition: x-x-x-4-5-x-x-x

4. Port Blinking

① Press the "PBL" key on the transmitter, and the light of the Port Blinking key will be on and at the same time the port blinking indicator will light up.

② Insert the network line into the RJ45 interface on the top of the transmitter and connect the other end to the switch/router.

③ Here, the port blinking indicator blinks every 3-4 seconds and drives the corresponding interface indicator on the switch/router to blink every 3-4 seconds synchronously. The target port can be judged.

Note: When connecting the PoE, the power supply wire core can be detected synchronously, which is shown by the green light of the wiring sequence indicators.

5. Telephone Line Detection

Push the switch on the transmitter to "Telephone Line". Insert the telephone line into the RJ11 interface on the top of the transmitter. The results are as follows:

① Telephone line polarity detection

When the green light is given, the 3P of the telephone line is positive and the 4P is negative.

When the red light is given, the 3P of the telephone line is positive and the 4P is negative.

② Telephone set status detection*

The indicator is on—The telephone set is idle

The green light and red light blink alternatively—The telephone set rings

The indicator becomes dark—Offhook (The telephone line is busy)

Note: * The color of the indicator is based on telephone line polarity detection.

Product Parameters

Model	NF-859GE (859G+802G main machine)	
Wire Detection Function	Anti-interference mode/ordinary mode	
Low Battery Prompt Function	✓	
Transmitter	Alignment Test	Remote alignment test and switch alignment test
	Crimping Response Speed	<1s
	Port Blinking Test	10M/100M/1000M
	Applicable Network Cable	CAT5 CAT6
	Standby Current	Alignment Test, wire detection and crimping<25mA Port Blinking<150mA
	Power Supply	3.7V, 1400mAh lithium polymer battery
	Interface Type	RJ 11, RJ 45
Dimension of Transmitter	60x135x30mm	
Receiver	Wire Detection Function	Anti-interference mode/ordinary mode (used with other models)
	Alignment Test	Local alignment test and remote alignment test
	Crimping Test	To test whether the registered jacks RJ11 and RJ45 are crimped properly
	PoE	Power supply wire core, mid-span and end-span
	VFL	10mW
	LED Flashlight	✓
	Battery Indication	✓
	Power Supply	3.7V lithium polymer battery
Dimension of Receiver	200x52x33mm	

NF-859GS (859G+8209S Transmitter)

The functions of the transmitter include alignment test, wire detection, length test, PoE test, port blinking and crimping test functions.



Use Instructions

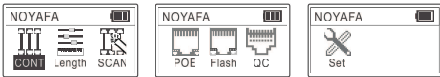

- Alignment Test: Normal, Cross, Short Circuit, Open Circuit.
- Length Test: Network line length breakpoint test, without calibration.
- Wire Detection Mode: Ordinary mode/anti-interference mode.
- PoE Test: Power supply wire core and power supply voltage detection. Both standard and nonstandard PoE can be tested.
- Port Blinking: The network line is quickly located on the switch/router.
- Crimping Test: To test whether the registered jack is crimped properly.

1. Power-on and Power-off

Transmitter: Long press the Power key to power on the instrument; long press it again to power off the instrument.

Receiver: Push the switch to power on or off the instrument.

2. Alignment Test Function

The alignment test function mainly tests the cable continuity, cross and short circuit states of the network line.

Connect one end of the cable to the "Wire/Line Test" interface on the right side of the transmitter, and the other end to the "Remote Line A" port at the bottom of the receiver. Press the confirmation button to start line testing.

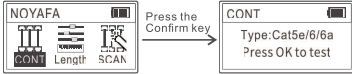

Operation Chart

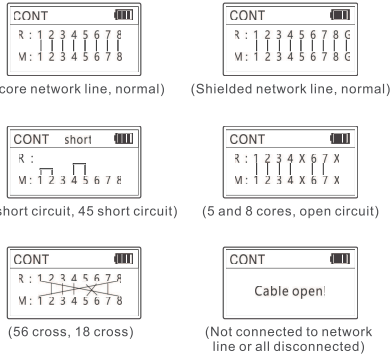

Test Results

3. Length Test

In length measurement, the network line must be no-load and must not be connected to any equipment. The best measurement range is 2.5 m – 200 m. If the measurement range is exceeded, the test result may be inaccurate.

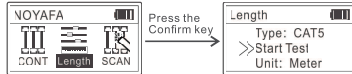

Insert one end of the network line under test into the left length test interface on the top of the transmitter and the other end should be no-load. Press the Confirm key to conduct the length test.

The test results are displayed in four groups, corresponding to the 12, 36, 45 and 78 twisted pairs respectively.

12: 80.8m
36: 12.1m
45: 80.8m
78: 80.8m

Displayed Result – 1
(The length of the network line is 80m. The 3 and 6 cores are faulty)

Cable open!
or length is beyond!

Displayed Result – 2
(The network line is not inserted or the measurement range is exceeded)

4. Wire Detection Function

Insert one end of the target network line into the right wire detection interface on the top of the transmitter (insert the telephone line into the telephone detection interface on the right side). Select a wire detection mode and use the receiver to locate the target line.

The nearer the probe head on the receiver to the target line, the stronger the signal and the brighter the indicator.

The adjustment knob on the right side of the receiver can be used to adjust the sensitivity.

The wire detection modes include "anti-interference wire detection" and "ordinary wire detection" modes.



Operation Chart

Note: The wire detection mode on the receiver should be consistent with that on the transmitter. (Press the wire detection on the receiver to switch the mode), otherwise, no signal will be received.

5. PoE Test Function

Connect the equipment under test to the PoE interface on the top of the transmitter. Press the Confirm key to display the test results.

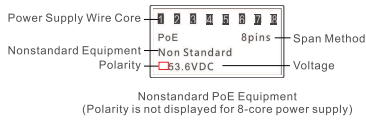
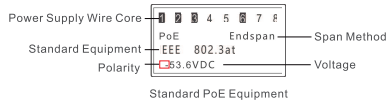
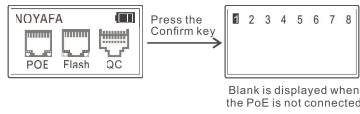

6. Port Blinking Function/Link Test

Port Blinking: Insert the network line into the left "Port Blinking" interface on the top and the other end to the switch/router. Select the "Blinking" test, and "Testing..." will be displayed on the screen. Here, the indicator corresponding to the switch/router will blink about every 3 seconds, and the target port can be judged.

Link Test: When the port blinks, the Link test is conducted automatically and the screen will display the rate, full duplex / half duplex and auto-negotiation/ non-auto-negotiation of the switch/router.

Error Prompt: "Test timeout" The causes may include

1. The operation is wrong.
2. The network line is not connected properly or is faulty.
3. The instrument is faulty.
4. The switch/router is faulty or is inconstant with the instrument.



7. Crimping Test

This function is used to test whether the registered jack is crimped properly.

Turn on the crimping test function and insert the registered jack into the "Crimping/Alignment Test" interface on the right side of the transmitter. "√" indicates the crimping is normal and "X" indicates the crimping is improper.



The crimping is normal

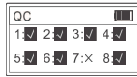

Example: Wire core 7 is not crimped properly

8. Transmitter Setup Function

Language, backlight time, time before automatic power-off, contrast, version number, etc.

Product Parameters

EMITTER	Wiremap	Cable type	CAT5/CAT6
		Cable sequence and fault testing	Normal, open circuit, short circuit, cross
		STP/UTP	Distinguishable by test
		MAX range	600M
	QC Test	Test type	8P
		Response speed	≤1S
		Minimum recognition	10cm
	Length	Test line	CAT5, CAT6
		Test range	2.5-200m
		Accuracy	≤20m±1.6m 20-100m±2.4m >100m±3.2m
		Unit	m/ft/yd
	SCAN	Cable type	CAT5/CAT6
		Max. signal voltage	5V±1.0VP-P
		Frequency	455KHz
		Dual mode	Analog/Digital mode
	POE	MAX range	600M
		Voltage test range	DC5-60V
		Power supply core/jumper mode	end jumper/middle jumper / 8-core power supply / unknown
	Flash	PSE type	non-standard, IEEE802.3at/af
		Full-duplex and half-duplex identification	Yes
Auto-Nego/Non-Auto-Negot		Yes	
	Switch type	10M/100M/1000M	

EMITTER	LCD display	128*64 Dot-matrix with backlight
	Language display	Chinese / English
	Keys	4 functions +1 power button
	Ports	Three RJ45+one RJ11
	Power supply	3.7V 1400mAh polymer lithium battery
	Battery low indication	yes
	Auto-off time	15min/30min/60min/OFF
	Voltage protection	DC60V
	Maximum working current	≤200mA
	Size	125x70x32mm
RECEIVER	Wire Detection Function	Anti-interference mode/ordinary mode (used with other models)
	Alignment Test	Local alignment test and remote alignment test
	Crimping Test	To test whether the registered jacks RJ11 and RJ45 are crimped properly
	PoE	Power supply wire core, mid-span and end-span
	VFL	10mW
	LED Flashlight	√
	Battery Indication	√
	Power Supply	3.7V lithium polymer battery
Dimension of Receiver	200x52x33mm	

Simple Fault Description

Result	Reason or solution
Different testing results for one same cable	Check whether the cable ends are connected well Keeps the ports clean
Length measured 0.0m	Connects to wrong port, "Length/Flash is the correct one." Make sure the tested cable length is 2.5m-200m
No results display when test PoE	Connects to wrong port, "PoE" is the correct one Test the cable's continuity to make sure it is a good cable Check the PoE device is power on
No flashing port when use port flash	Connects to wrong port, "Length/Flash" is the correct one Test the cable's continuity to make sure it is a good cable Check the router or switch is on
No tone when track cable	Connects to wrong port, "SCAN" is the correct one The mode of transmitter and receiver must keep the same Check whether the battery is low Turn up the sensitivity
The text on screen is blurry	Adjust the contrast to suit yourself
Turn on the device and auto-off soon	Replace a new battery

NF-859GK (859G+8506 Transmitter)

The functions of the transmitter include wire detection, alignment test, length test, port blinking, network port rate, PoE, PING test, IP scanning, etc.



Icons on UI



AUTO-OFF: Customers can see the icon " " on the left top of the screen when the function is ON, Customers can choose to turn it off in "Set".



Power Level: Show the battery power level of the device, it will turn to Green when charging, and stays white when in use.



Cable Continuity Test



Cable Tracking



Port Flash



Cable Length Measurement



PoE Test



PING Ping Test



IP Scan



Switch Test



Set

User Instructions

1. Alignment Test

Three alignment test modes: Alignment test with receiver, alignment test with switch, and local alignment test.

Alignment Test with Receiver: To test the cable continuity, cross and short circuit of the network line.

Alignment Test with Switch: To test the cable continuity only, which is shown in the form of short circuit.

Local Alignment Test of Receiver: You can switch between fast alignment test and slow alignment test.

Take Alignment Test with Receiver as an example.

Insert one end of the cable into the line interface on the right side of the transmitter, and the other end into the "Remote Line A" port at the bottom of the receiver. Select "Line with Receiver" and press the "OK" button to start the test. The test results are as follows:

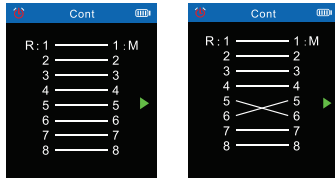

The test is normal

Cross of cores 5 and 6

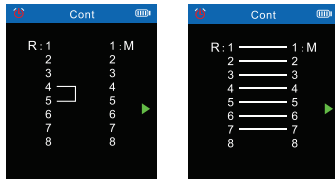

Short circuit of cores 4 and 5

Open circuit of core 8

2. Wire Detection

Press the Up/Down key to switch between the two wire detection modes.

Anti-interference Wire Detection: Anti-interference and noise-free. This mode is recommended for the on-load wire detection of a gigabit switch.

Ordinary Wire Detection: With certain noise. The ordinary wire detection mode can be used to detect ordinary electric cables or for no-load wire detection.

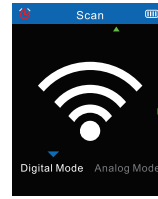

Digital Mode

Transmitter:

The default mode is the anti-interference wire detection mode. Press the Up/Down key to switch between the anti-interference wire detection mode and ordinary wire detection mode.

Receiver:

The default mode is the anti-interference wire detection mode. Press the Wire Detection key to switch between the anti-interference wire detection mode and ordinary wire detection mode. When the light of the Wire Detection key is on, it indicates the anti-interference wire detection mode; when the light of the Wire Detection key blinks, it indicates the ordinary wire detection mode.

Notes:

1. The mode on the transmitter should be consistent with that on the receiver, otherwise, the receiver cannot detect any signal.
2. The knob on the receiver is used to adjust the sensitivity of wire detection. The maximum detection range is 10cm; the maximum wire detection distance is 600m for no-load wire detection or 1000m for on-load wire detection.
3. The stronger the signal received, the brighter the signal strength indicator.

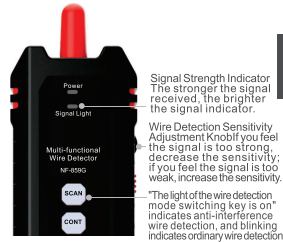

Signal Strength Indicator
The stronger the signal received, the brighter the signal indicator.

Wire Detection Sensitivity Adjustment Knob
If you feel the signal is too strong, decrease the sensitivity; if you feel the signal is too weak, increase the sensitivity.

The light of the wire detection mode switching key is on, indicates anti-interference wire detection, and blinking indicates ordinary wire detection.

3. Port Blinking

When the detection is successful, the green spot displayed on the interface will blink with the port indicator synchronously.

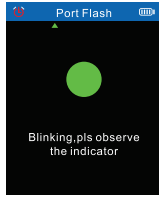

Port Flash

4. Network Line Length Test

The length of the network line can be tested. After setting the type and unit of the network line, press the "Start" key to start the test. The length is displayed in line pairs. (Best Measurement Range: 5-200m)

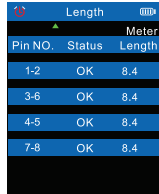

Network Line Length Test

5. PoE Test Function

When the detection is successful, the screen will display the detection data.

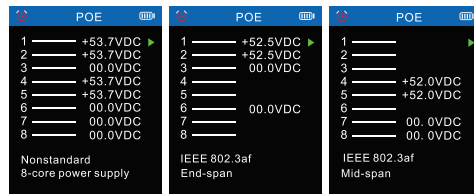

8-core power supply, 53.7V

End-span, 52.5V

Mid-span, 52.0V

PoE: 5~60V nonstandard/standard PoE can be tested. The AF/AT standard is identified automatically.

6. PING Test Function

Press the "Ping" or "Set IP" key to select PING or IP. For the first time of use, it is suggested that you first enter the Set IP interface to set the IPv4 parameters. After all parameters are set, press the "Ping" or "Set IP" key to go to the Ping option and start the test.



PING Test Function



Set IP

7. IP Scanning Function

Press the "▲" or "▼" key to select Scan or Set IP. After all parameters are set, press the "▲" or "▼" key to go to the Scan option and start the IP scanning.



IP Scan

8. Network Port Rate Test

When the detection is successful, the rate (10M/100M/1000M) and the duplex mode (full duplex/half duplex) of the network port will appear.

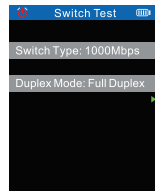

Switch Test

Ps: When the detection is successful, if the network port is switched, you need to quit and redo the test to ensure the detection data are accurate.

What the function tests is the rate class (10M/100M/1000M) of the network port on the router/switch, rather than the real-time rate of the network.

9. Transmitter Setup Function

Language, backlight brightness, backlight time, automatic power-off, factory default, viewing local information, etc.

Product Parameters

Model	NF-859GK (859G+8506 Main Machine)		
Cable Scan	Digital Mode / Analog Mode		
Auto OFF	✓		
Low Power Notice	✓		
Transmitter	Cable Continuity Test	Remote & Switch	
	Cable Length Test	Range: 5~200m (±3m)	
	Port Flash	10M/100M/1000M	
	POE	Mid-Span/End-Span/AT-4 pairs	
		PoE voltage test	
	Link Speed	10M/100M/1000M	
		Duplex Mode (Full Duplex/ Half Duplex)	
	Battery	3.7V Lithium Battery	
	Ping Scan Function	✓	
	IP Scan Function	✓	
Transmitter Dimension	150×75×35mm		
Receiver	Wire Detection Function	Anti-interference mode/ordinary mode (used with other models)	
	Alignment Test	Local alignment test and remote alignment test	
	Crimping Test	To test whether the registered jacks RJ11 and RJ45 are crimped properly	
	PoE	Power supply wire core, mid-span and end-span	
	VFL	10mW	
	LED Flashlight	✓	
	Battery Indication	✓	
	Power Supply	3.7V lithium polymer battery	
	Dimension of Receiver	200x52x33mm	

NF-859GT (859G+8508 Transmitter)

The functions of the transmitter include alignment test, wire detection, port blinking, length test, PoE test, crimping test, optical power meter and red light functions.



Icons on UI



AUTO-OFF: Customers can see the icon "🔌" on the left top of the screen when the function is ON, Customers can choose to turn it off in "Set".



Power Level: Show the battery power level of the device, it will turn to Green when charging, and stays white when in use.



Cable Continuity Test



Cable Tracking



Port Flash



Cable Length Measurement



PoE Test



PING Ping Test



IP Scan



Switch Test



Set

User Instructions

1. Alignment Test

Three alignment test modes: Alignment test with receiver, alignment test with switch, and local alignment test.

Alignment Test with Receiver: To test the cable continuity, cross and short circuit of the network line.

Alignment Test with Switch: To test the cable continuity only, which is shown in the form of short circuit.

Local Alignment Test of Receiver: You can switch between fast alignment test and slow alignment test.

Take Alignment Test with Receiver as an example.

Insert one end of the cable into the line interface on the right side of the transmitter, and the other end into the "Remote Line A" port at the bottom of the receiver. Select "Line with Receiver" and press the "OK" button to start the test. The test results are as follows:

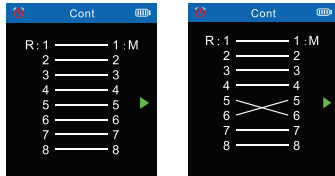

The test is normal

Cross of cores 5 and 6

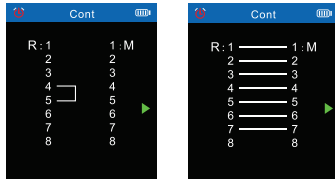

Short circuit of cores 4 and 5

Open circuit of core 8

2. Wire Detection

Press the Up/Down key to switch between the two wire detection modes.

Anti-interference Wire Detection: Anti-interference and noise-free. This mode is recommended for the on-load wire detection of a gigabit switch.

Ordinary Wire Detection: With certain noise. The ordinary wire detection mode can be used to detect ordinary electric cables or for no-load wire detection.

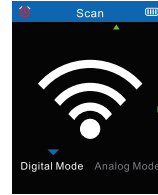

Digital Mode

Transmitter:

The default mode is the anti-interference wire detection mode. Press the Up/Down key to switch between the anti-interference wire detection mode and ordinary wire detection mode.

Receiver:

The default mode is the anti-interference wire detection mode. Press the Wire Detection key to switch between the anti-interference wire detection mode and ordinary wire detection mode. When the light of the Wire Detection key is on, it indicates the anti-interference wire detection mode; when the light of the Wire Detection key blinks, it indicates the ordinary wire detection mode.

Notes:

1. The mode on the transmitter should be consistent with that on the receiver, otherwise, the receiver cannot detect any signal.
2. The knob on the receiver is used to adjust the sensitivity of wire detection. The maximum detection range is 10cm; the maximum wire detection distance is 600m for no-load wire detection or 1000m for on-load wire detection.
3. The stronger the signal received, the brighter the signal strength indicator.

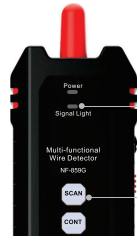

Signal Strength Indicator
The stronger the signal received, the brighter the signal indicator.

Wire Detection Sensitivity Adjustment Knob if you feel the signal is too strong, decrease the sensitivity; if you feel the signal is too weak, increase the sensitivity.

The light of the wire detection mode switching key is "on" indicates anti-interference wire detection, and blinking indicates ordinary wire detection.

TC9508

3. Port Blinking

When the detection is successful, the green spot displayed on the interface will blink with the port indicator synchronously.

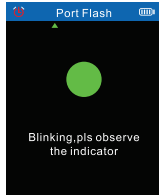

Port Flash

4. Network Line Length Test

The length of the network line can be tested. After setting the type and unit of the network line, press the " " key to start the test. The length is displayed in line pairs. (Best Measurement Range: 5-200m)

Pin NO.	Status	Length
1-2	OK	8.4
3-6	OK	8.4
4-5	OK	8.4
7-8	OK	8.4

Network Line Length Test

5. PoE Test Function

When the detection is successful, the screen will display the detection data.

POE	POE	POE
1 +53.7VDC	1 +52.5VDC	1
2 +53.7VDC	2 +52.5VDC	2
3 00.0VDC	3 00.0VDC	3
4 +53.7VDC	4	4 +52.0VDC
5 +53.7VDC	5	5 +52.0VDC
6 00.0VDC	6 00.0VDC	6
7 00.0VDC	7	7 00.0VDC
8 00.0VDC	8	8 00.0VDC

Nonstandard 8-core power supply, 53.7V IEEE 802.3af End-span, 52.5V IEEE 802.3af Mid-span, 52.0V

PoE: 5~60V nonstandard/standard PoE can be tested. The AF/AT standard is identified automatically.

6. Crimping Test

This function is used to test whether the registered jack is crimped properly. A tick indicates the wire core is crimped properly. A cross indicates the wire core is not crimped properly.

QC Test	QC Test	QC Test
1 x	1 ✓	1 ✓
2 x	2 ✓	2 ✓
3 x	3 ✓	3 ✓
4 x	4 x	4 ✓
5 x	5 x	5 ✓
6 x	6 ✓	6 ✓
7 x	7 ✓	7 ✓
8 x	8 ✓	8 ✓

Cores 1-8 are all not through Cores 4 and 5 are not through The crimping is normal

- 10/26/2018

- 10/26/2018

7. Optical Power Meter Function

This function is used to test optical power and light attenuation values. The unit, wavelength, REF and optical power calibration can be set. The current option is indicated with a white triangle cursor.

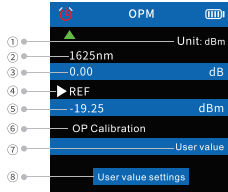

① Unit Setup: dbm or nw

Press the Up/Down key to move the cursor to this item, and press the "OK" key to switch the unit.

② Wavelength Setup: 850, 1300, 1310, 1490, 1550, 1625nm

Press the Up/Down key to move the cursor to this item, and press the "OK" key to switch the wavelength.

③ Optical Power: After the wavelength is set, insert the optical fiber into the optical power interface on the top of the instrument. The 3rd line display the optical power value.

④ REF: Reference value. Use it when testing the attenuation value after the optical signal passes through the optical fiber link.

- After testing the optical power value, move the cursor to REF. Long press the "OK" key for 3 seconds, and the optical power value will jump from the 3rd line to the 5th line and become a reference value.
- Access the optical fiber link to be tested. Here, the 3rd line displays the attenuation value of this optical fiber link (Test value after the optical fiber link is accessed - Reference value before the optical fiber link is accessed = Attenuation value of this optical fiber link).
- Press the "OK" key to turn on/off the REF mode. Long press the "OK" key for 3 seconds to reset the reference value.

⑤ Reference Value: When it is not in the REF mode, the 3rd line displays the optical power value and the 5th line does not display any values.

Notes:

- In the REF mode, the 5th line displays the reference value, and the 3rd line displays the attenuation value.
- dbm stands for the unit of the absolute power value.
- dB is a relative figure and stands for increase or decrease of signal strength.
- In the optical fiber network, optical power is often measured with dBm as the unit, and optical fiber attenuation, loss and insertion loss are represented using dB.

⑥ Optical Power Calibration: Factory-set value/ user-defined value

In normal cases, just select the factory-set value. When the test error is big, you can select User-Defined Value — User-Defined Value Setup for calibration.

The following uses the 1310 wavelength as an example:

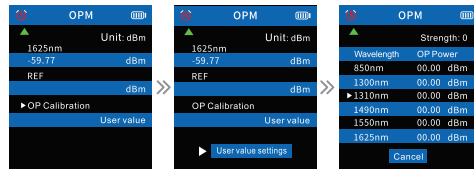

Select Optical Power Calibration Press the "OK" key to switch between the factory-set value/ user-defined value.

Select User-Defined Value Setup Press the "OK" key to enter the Setup interface.

Press the "Up/Down" keys and select the wavelength 1310. Then press the "OK" key to enter Parameter Setup.



Press the "OK" button to switch between integer and percentage. Press the "Left" and "Right" keys to set the parameters. After the parameters are set, press the "OK" key.

The cursor is in front of 1310 again. Long press the "OK" key for 2 seconds. When "√" appears, it indicates confirmation.

Press the "ESC" key to return to the Test interface. Here, you can test the optical power again.

Notes:

- In Step Five above, be sure to long press the "OK" key for 2 seconds. When "√" appears, it indicates that the data are confirmed; otherwise, the calibration will take effect.
- In the aforementioned step six, calibration is done for the 1310 wavelength. When testing the 1310 wavelength under "User Value Setting" mode, the calibration data takes effect. For calibration in other wavelengths, follow steps three hundred and forty-five as described above.
- If the calibrated value is not used, switch back to the factory-set value according to Step One above.
- To remove the calibrated value, return to Menu — Setup — Factory Settings.

8. Red Light Function

Transmitter:

Select the "Light" function to turn on the red light. Press the "OK" key to switch between Fast Blinking, Slow Blinking and On.

Receiver:

Press the "VFL" key to turn on the red light. Press it again to switch between On, Blinking and Off.

9. Setup Function

On the transmitter, the language, backlight brightness, backlight time and time before automatic power-off can be set.

Product Parameters

Model		NF-8508	
Cable type		CAT5/CAT6	
Voltage protection		60V	
Battery		Type C charge	
Transmitter	CONT	Wiremap Port	RJ45
		MAX range	300m
		STP/NTP	√
		Digital mode and Analog mode	√
	Scan	Frequency	455KHz
	Port Flash	Full duplex / Half duplex	
		Auto-Nego / Non-Auto-Nego	Automatic Identification
	Length	10m/100m/1000m	
		≤20M+/-1.6M, 20M-100M+/-2.4M, ≥100M+/-3.2M	
	PoE	Standard/Non standard	
		End connection / Middle jumper / Powered by 8 cores	Automatic Identification
		PoE Power supply	Voltage detection
VFL	10mW		
Power meter	850/1300/1310/1490/1550/1625 (Wavelength)		
Crimping	RJ45-8 Cores, Min length is ≥10cm		
Lower voltage warning	< 3.5V ± 0.1V		
Power supply	3.7V 1500mAh Polymer lithium battery		
Transmitter size	148 X 70 X32 mm		
Receiver	Wire Detection Function	Anti-interference mode/ordinary mode (used with other models)	
	Alignment Test	Local alignment test and remote alignment test	
	Crimping Test	To test whether the registered jacks RJ11 and RJ45 are crimped properly	
	PoE	Power supply wire core, mid-span and end-span	
	VFL	10mW	
	LED Flashlight	√	
	Battery Indication	√	
	Power Supply	3.7V lithium polymer battery	
Dimension of Receiver	200x52x33mm		

NF-8508



精明鼠

深圳市诺方舟电子有限公司

编号	201	202	301	302	303	304	305	比例:	1:1	品号:	304-A0912-0002
类目	塑胶件	五金类	镜片	PVC贴纸	不干胶贴	说明书	包装盒	单位:	mm		
选择						√		设计	CZG	品名:	NF-859G系列说明书骑马订英文-V2 20240320
306	307	308	309	310	311	312	313	核准			
彩卡	吸塑	工具包	PE袋	纸箱	宣传单	合格证	打印标签	标准:	√	文件类型:	做货文件
								定制:			
制作日期	2024.03.20			样式	骑马订	印刷材质		128g双铜纸			
印刷要求	彩色			页码	44P	变更记录		V2较V1版本,更新了功能说明			
尺寸大小	140*105mm			版本	V2						